

**SIDE DUMP TRAILER**

**DEMCO**

**Get in and out  
of the job site faster**



# SIDE DUMP

**TRAILERS**



**DEMCO**

[www.demco-products.com](http://www.demco-products.com)  
1.800.543.3626

# Superior Handling and Stability

- One of the **lowest center of gravity tubs on the market** - increases safety by being more stable and reducing twisting of the tub.
- Registered **Trademarked FlexCorners®** - allows for flexibility of the tub to reduce cracking in the corners when the load or terrain is uneven.
- The ability to **switch dump direction** - no need to walk around the trailer to change directions.
- **Press Breaks in Tub** -
  - 1) Enables the material to roll over itself and allows the tub to dump smoother, faster, and cleaner!
  - 2) Prevents huge transfers of weight that causes wheel hop and trailers to tip over.



**Demco Side Dump Trailers are your #1 choice for safety and productivity.**

**OPTIONS** See more options on next page

## DOLLIES AND TURNTABLES



Dollies and Turntables Standard Model Variations  
Tongue lengths varying from 33" - 225"

## HIGH CAPACITY KITS



### High Capacity Kit

20' Tub	22.3 cu. yds.
34' Tub	38.4 cu. yds.
37' Tub	41.5 cu.yds



### XL High Capacity Kit

20' Tub	27.5 cu. yds.
34' Tub	47.3 cu. yds.
37' Tub	51.1 cu.yds

# FEATURES

## TUB

- Made with 1/4" AR450 Steel - a high-carbon alloy abrasion resistant steel
  - Optional 3/16" AR450 Tub Walls
- 3 integrated tub pivot points with greaseless pivot bearings
- Tub dump direction controlled from two places on the left side - no need to walk all around the trailer to change dump direction
- Tub dump direction indicators visible in truck mirrors
- Rubber EdgeFlex fenders with bolt-on mounts - easily replace damaged fender parts
- Large Single GRail on Tub - lighter and stronger than two rail systems
- FlexCorner® design
- Standard Color: Black (Custom colors available)
- Tub drains standard

## CHASSIS

- 20" deep twin "I" beam chassis with 3/8" kingpin plate
- Holland Atlas 55 Landing Gear w/ 2 speed gear box
- Holland CBX 23,000 lb, 5-3/4" OD axle
- Haldex 2S1M ABS system
- Brakes: Drum Brakes standard (Disc Brakes optional)
- Suspensions: SAF-Holland CBX23-245 Air Suspension w/ Integrated Axles (Watson-Chalin lift and steer axles on Quint, Quad, and Trains) Spring Ride suspension available
- Wheel & Tire Options: 11R22.5 or 11R24.5 on Steel or Aluminum Rim, 385/65R22.5 Super Singles on Aluminum Rim (Other sizes available upon request)
- Hydraulic System: 3000 psi rated 3/4" Hoses, Fittings, Flow Divider, and Relief Valve. Trailer Mounted Electric Over Hydraulic Control Valve Available

- Twin 3000 psi rated 5" cylinders (Optional 6" cylinders available)
- Standard LED lights in enclosed boxes with sealed plugs
- Bolt-on Push block with Under Ride Bumper conform to Federal Motor Vehicle Safety Standards

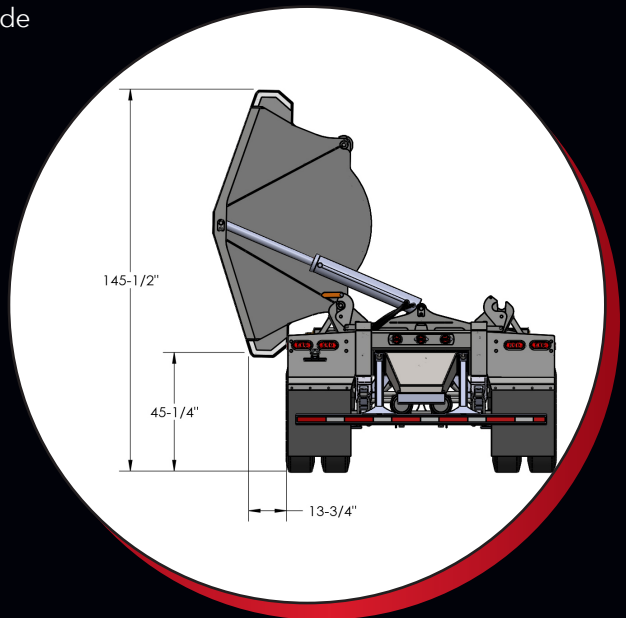

## TARPS



Aero Electric Tarps



Roll Rite Electric Tarps



*"We have had zero issues with it and would not change one single thing on the next trailer!"*

**MIKE SIMON**  
INDIANA

Allows flexing between main body and G-Rail



**STRONGER G-RAIL**

The larger G-Rail distributes weight evenly across the tub, **preventing it from bowing under heavy loads.** Additionally, our G-Rail helps keep materials away from the tires and wheels, reducing the risk of damage.

**OPTIONS**



**PUSH BLOCK W/ UR BUMPER**



**PUSH BLOCK**  
Bolt-on Push/Lift block with stub bumper  
**REAR STROBE LIGHTS**  
For safety and visibility



**PUSH BLOCK W/ PINTLE HITCH**



**FULL WIDTH MUDFLAP**  
Available on front and rear



**BRAKE LINES**



**INSIDE OF TUB**

Quick and easy clean-out with no exceptions

**NO MORE CORNER CRACKING**

The Registered Trademarked FlexCorner® design **allows for flexibility to maintain the structural integrity of the tub and eliminates cracking.**

**SMOOTH DUMPING**

Three pivot points distribute weight across the frame more effectively than two, **resulting in a smoother dumping process and reduced frame vibration or chatter while driving.** This design also places less stress on the frame.

**PULLS SMOOTH**

The tub in our design sits lower within the frame, unlike other side dump trailers where you can see daylight between the frame and the tub. This lower placement creates a lower center of gravity, **resulting in a smoother, safer ride with no offside wheel hop.**



**HOSE HANGER**

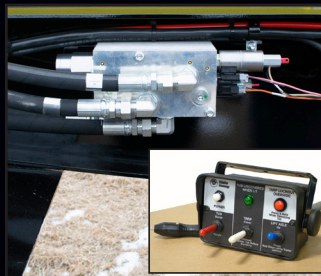

**EOH VALVE AND CONTROL BOX**



**DISC BRAKES**

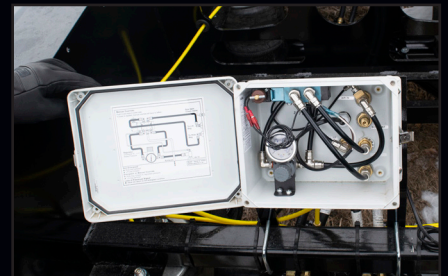

**LIFT AXLE CONTROL VALVE ASSEMBLY**

## TandemAxle

Model	Suspension	Chassis Length	Wheel Base	Axle Spacing	Tub Length	Tub Volume*	Tare Weight	Optional 37' Tub
35' Tandem	Air Ride	35'-4"	324.5"	49"	30'-3"	20.1 cu. yd.	13,640 lbs	NA
40' Tandem	Air Ride	40'-5"	383"	49"	34'-3"	22.7 cu. yd.	15,680 lbs	NA

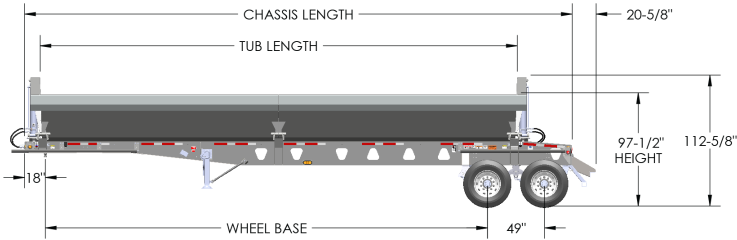

## TriAxle

Model	Suspension	Chassis Length	Wheel Base	Axle Spacing	Tub Length	Tub Volume*	Tare Weight	Optional 37' Tub
35' Tri-Axle	Air Ride	35'-4"	324.5"	49"	30'-3"	20.1 cu. yd.	16,500 lbs	NA
40' Tri-Axle	Air Ride	40'-5"	383"	49"	34'-3"	22.7 cu. yd.	17,000 lbs	NA
42' Tri-Axle	Air Ride	42'-1"	404"	49"	34'-3"	22.7 cu. yd.	17,500 lbs	NA
44' Tri-Axle	Air Ride	44'-2"	428"	49"	34'-3"	22.7 cu. yd.	17,900 lbs	24.5 cu.yd.
44' Tri-Axle	Spread Air Ride	44'-2"	417"	60"	34'-3"	22.7 cu. yd.	17,900 lbs	24.5 cu.yd.
46' Tri-Axle	Air Ride Closed/ Open	45'-8"	377"	49" / 79"	34'-3"	22.7 cu. yd.	18,000 lbs	NA
47' Tri-Axle	Air Ride Closed/ Open	47'-2"	395"	49" / 79"	37'	NA	18,200 lbs	24.5 cu. yd.

### Air Ride and Spread Air Ride

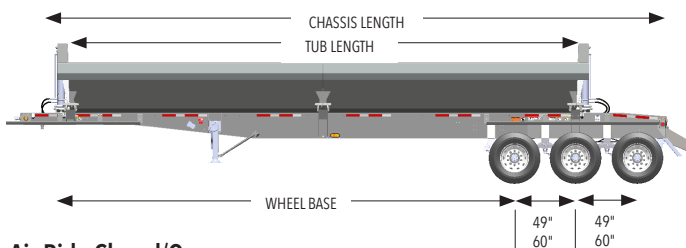

### Air Ride Closed/Open

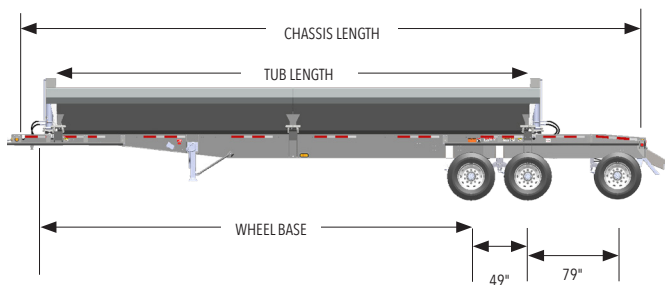

*NOTE: Heights measured with 11R22.5 tires.*

\* Water level capacity

## QuadAxle

Model	Suspension	Chassis Length	Wheel Base	Axles 1-2	Axles 2-3	Axles 3-4	Volume* 34' 3" Tub	Tare Weight	Optional 37' Tub
44' Quad Rear Lift	Air Ride	44'-4"	330"	49"	49"	49"	22.7 cu. yd.	18,500 lbs	24.5 cu.yd.
44' Quad Rear Lift Lift/Steer	Air Ride	44'-4"	335"	49"	49"	60"	22.7 cu. yd.	19,200 lbs	24.5 cu.yd.
47' Quad FL/RLS	Air Ride	47'-2'	395"	49"	49"	60"	NA	19,500 lbs	24.5 cu. yd.

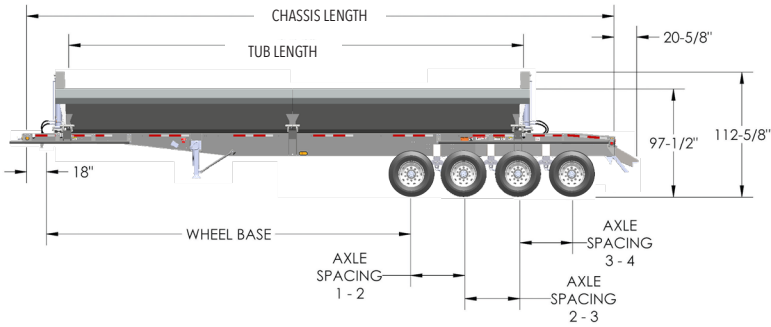

## QuintAxle

Model	Suspension	Chassis Length	Wheel Base	Axles 1-2	Axles 2-3	Axles 3-4	Axles 4-5	Volume* 34' 3" Tub	Tare Weight	Optional 37' Tub
44' Quint	Air Ride	44'-4"	243 1/32"	97"	49"	49"	49"	NA	20,800 lbs	24.5 cu.yd.

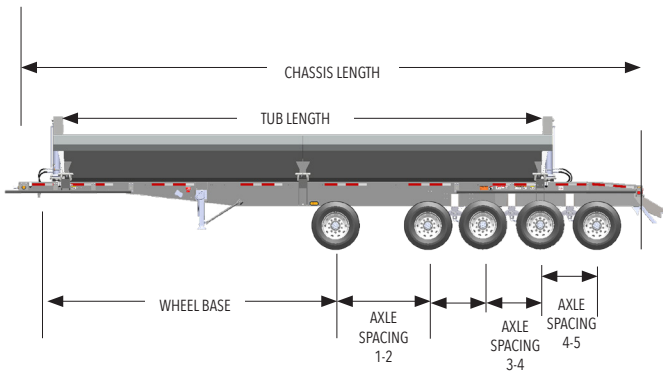

## Trains



**Maximum Payload  
Maximize Profit**

## Pup Trailers with Turntables

- 26' with 20' Tub - 2 Axle, 3 Axle, or 4 Axle Air Ride
- 30' with 24' Tub - 4 Axle Air Ride

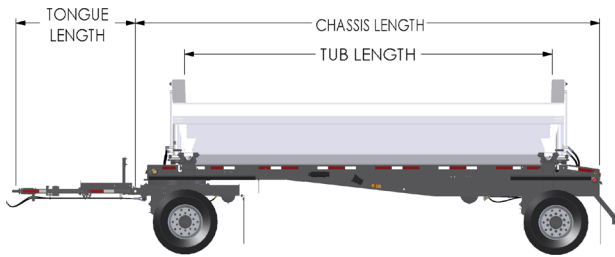
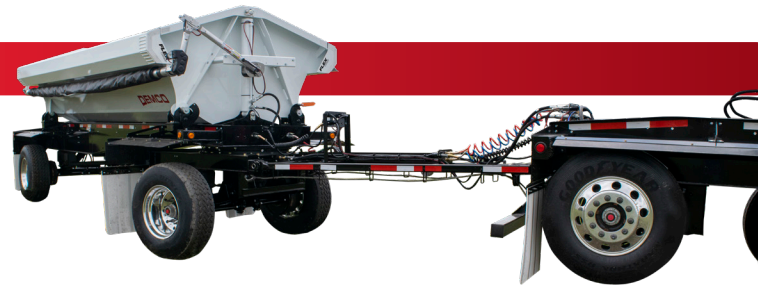

Model	Suspension	Tub Length	Tub Volume	Tare Weight
26'	Air Ride	20'	13.5 cu. yd.	2 Axle-12,500 lbs
26'	Air Ride	20'	13.5 cu. yd.	4 Axle-15,800 lbs
30'	Air Ride	24'	16 cu. yd.	11,500 lbs

## Truck Box Side Dump



- One Year Warranty on Manufactured Parts
- Dumps to Left or Right Side
- Quick Side-to-Side dump change
- 20 Second dump (30 sec. cycle) at 33 GPM Flow
- Roll-Rite tarp option available
- May require EOH Valve
- Complete sub frame assembly-complete with wiring and lights
- Trademarked FlexCorner® Design

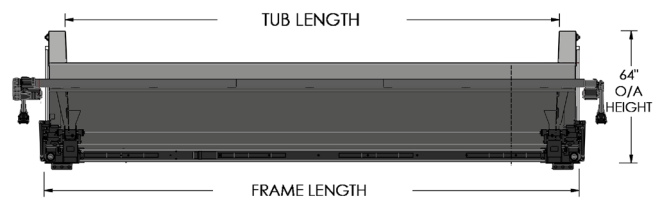

Model	Bolt on Sub-frame	Dump Body	Tub Capacity	Cylinder Diameter	Tare Weight
14'	15' 8 1/2"	14' AR450	9.3 cu. yds.	5"	4,700 lbs
15'	16' 8 1/2"	15' AR450	10 cu. yds.	5"	4,800 lbs
16'	17' 8 1/2"	16' AR450	10.75 cu. yds.	5"	5,020 lbs
17'	18' 8 1/2"	17' AR450	11.5 cu. yds.	5"	5,140 lbs
20'	21' 8 1/2"	20' AR450	13.5 cu. yds.	5"	5,475 lbs
24'	25' 8"	24' AR450	15.8 cu. yds.	5"	5,922 lbs



*Doing Our Best to Provide You the Best*

4010 320th Street • Boyden, Iowa 51234

1.800.543.3626

www.demco-products.com